

USE & CARE GUIDE

Waterwise 9000™

Countertop Steam Distiller

See It Work

www.waterwise.com

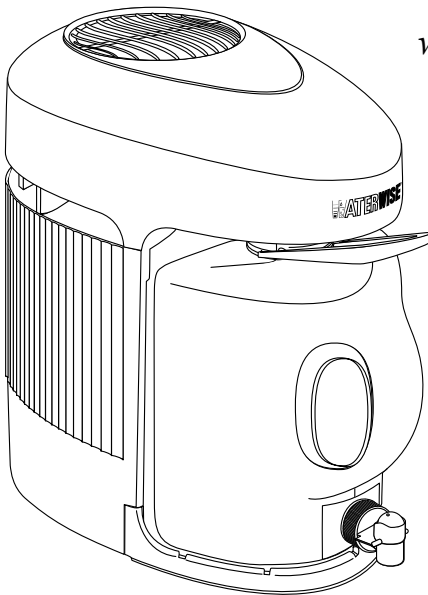

See important safeguards on pages 2 and 3



An exclamation point within an equilateral triangle is intended to alert user to the presence of important operating and maintenance instructions in the literature accompanying the appliance.



A lightning bolt within an equilateral triangle is intended to alert user to risk of injury from electric shock.



Water and steam vapor within an equilateral triangle is intended to alert user to risk of injury from boiling water and/or escaping steam.

IMPORTANT SAFEGUARDS

A person who has not read and understood all operating and safety instructions is not qualified to operate this appliance. When using this appliance, always adhere to basic safety precautions including:

READ ALL INSTRUCTIONS BEFORE USE.

1. Use **INDOORS** on a dry, level, well-supported, stable surface. **DO NOT** operate in a moving vehicle.
2. **DO NOT** change position or location of Distiller while it is operating or cooling. Water in the boiler is heated to boiling (212° F) and can cause severe burns.
3. **DO NOT** remove collector/dispenser bottle or boiler while Distiller is operating. Boiling water or steam can cause severe burns. Let cool at least 30 minutes after a cycle is finished before removing boiler cap.
4. **DO NOT** allow children to be near Distiller without close supervision. Boiling water will scald if spilled on skin. Warn other users of possible dangers from boiling water and/or escaping steam.
5. **DO NOT** place near an edge of a surface where Distiller can be bumped or pulled down on someone. **DO NOT** allow power cord or extension cord to hang over the edge of counter or contact hot surfaces.
6. A short power supply cord is provided to reduce risks resulting from becoming entangled in or tripping over a longer cord. If an extension cord must be used, its marked electrical rating must be at least as great as the electrical rating of the Distiller. Electrical rating is found on bottom of Distiller.
7. To protect against fire, electrical shock, and injury to persons, **DO NOT** immerse power cord or Distiller in water or liquid.
8. **DO NOT** operate with a damaged cord or plug, after a malfunction, or if the Distiller has been damaged in any manner. Return to an authorized service facility for examination and repair.
9. This Distiller is recommended for use with potable water only. **DO NOT** attempt to make safe drinking water from non-potable water sources. **DO NOT** use briny (sea) water as this will damage certain components and will void warranty.
10. Operate in a well-ventilated area away from other heat sources. Provide adequate air space (at least 4-6 inches from walls or cabinets) when in use. **DO NOT** place on or near a hot gas or electric burner, or in a heated oven. **DO NOT** place, store, or stack anything on top of or against sides of Distiller while in operation.



11. **DO NOT** operate without water in the boiler. Permanent damage may occur.
12. This Distiller requires no special care other than general cleaning (page 9) and periodic filter cup replacement (page 5). If servicing becomes necessary, contact an authorized dealer or authorized service facility. **DO NOT** attempt to repair Distiller yourself. There are **NO** user serviceable parts. See warranty for service details.
13. Unplug from wall outlet when not in use and before cleaning. Allow to cool at least 30 minutes before cleaning.
14. Make sure collector/dispenser bottle is properly placed, with its cap removed, for proper water collection. **DO NOT** remove collector/dispenser bottle while Distiller is operating.
15. **DO NOT FILL BOILER TANK ABOVE THE “MAXIMUM FILL POINT”** (fig. D).
16. **DO NOT** use appliance for other than intended use.



ELECTRIC CORD STATEMENT

CAUTION: Your Distiller has a short cord as a safety precaution to prevent injury or property damage resulting from pulling, tripping or becoming entangled with the cord. **DO NOT** allow children to be near Distiller without close adult supervision. If you must use an extension cord with Distiller, the cord must be arranged so that it will not drape or hang over the edge of a countertop or tabletop where it can be pulled on by children or tripped over. To prevent electric shock, injury or fire, the electrical rating of the extension cord you use must be the same as, or more than wattage of the Distiller (wattage is indicated on bottom of Distiller). Plug Distiller into rated voltage AC grounded electric outlet **ONLY** (rated voltage found on bottom of product). The cord has a three-prong plug which mates with a standard three-prong grounded wall outlet. **DO NOT** cut or remove third prong from plug. If an adapter is used, be sure adapter wire and wall outlet are grounded. If there is any doubt as to whether the outlet is properly grounded, check with a qualified electrician. Unplug Distiller when not in use.



WARNING: Never remove the boiler while the fan motor is running, or for 30 minutes after it stops. Severe burns can result from boiling water or steam. **DO NOT** change position or location of distiller while it is operating or cooling.

SAVE THESE INSTRUCTIONS

HOW IT WORKS

FIGURE A

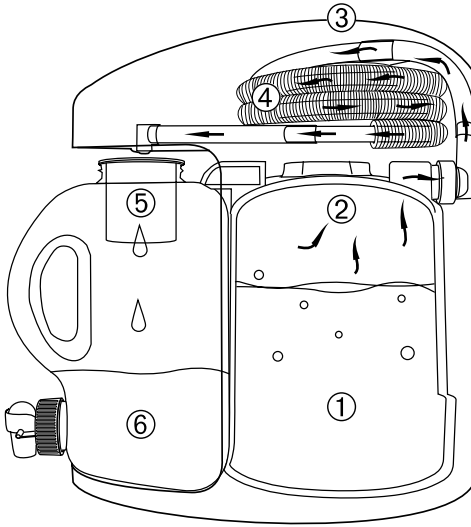

See It Work

www.waterwise.com



This Distiller produces purified water by using the oldest, most effective method of water treatment—steam distillation. When the Distiller is operating, the water temperature rises to 212°F (100°C), killing bacteria, cysts, and viruses that may be present. As the boiling water (1) converts to steam (2), it rises and leaves behind dead microbes, dissolved solids, salts, heavy metals, and other substances. Low boiling light gases that may be present are discharged through the gaseous vent (3). Steam is then cooled in the stainless steel condenser (4), turning it into high quality water. Distilled water percolates through a final polishing coconut shell carbon filter (5) to enhance quality by adsorption of VOCs (volatile organic compounds), and is then collected in the Tritan™ collector/dispenser bottle (6) which is Bisphenol-A (BPA) Free.

Tritan™ is a Trademark of Eastman Chemical Company

This system was tested and certified by the Water Quality Association against WQA S-400 for the reduction of TDS (Total Dissolved Solids). It has the product water production rate of 1 gallon per 4.5 hours and has the product water storage capacity of 1 gallon.

Waterwise 9000

Production rate: 5.5 gallons per day

	<i>Model</i>	<i>Volts</i>	<i>Hertz</i>	<i>Watts</i>
North America	9010	120 VAC	60 Hz	750W
North America	9012	120 VAC	60 Hz	750W
Europe	9024	230 VAC	50 Hz	730W
United Kingdom	9025	230 VAC	50 Hz	730W
Southeast Asia	9026	230 VAC	50 Hz	750W

PREPARING FOR FIRST TIME USE

Clean Collector/Dispenser Bottle

- Ensure the dispensing valve (fig. B) is installed and tightened.
- Fill bottle approximately three fourths full with warm tap water.
- Add one or two drops of dish detergent.
- **DO NOT** install filter cup at this time.
- Seal bottle opening with cap.
- Shake vigorously and drain.
- Rinse thoroughly.

- Add 6 ounces (180 ml) of 3 percent hydrogen peroxide to bottle.
- Fill with warm tap or distilled water (less than 120°F).
- **DO NOT** install the filter cup at this time.
- Seal bottle opening with cap.
- Shake vigorously and let stand for 20 minutes.
- Drain and rinse thoroughly.

Sterilize and Rinse Carbon Filter Cup

Before installing, fully immerse new filter cup in distilled water for about five minutes. Then sterilize filter cup by fully immersing in boiling water for about five minutes. Allow filter to cool before handling. Pour 1 to 2 cups distilled water through filter cup to rinse away any small, harmless carbon fines (dust). Water draining from the filter cup may contain black dust. This is typical. The carbon dust is formed as a result of production, packaging and shipping of filter cup.

FIGURE B

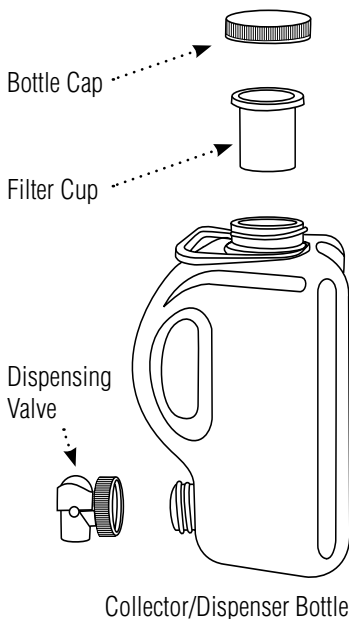

Install Filter Cup

Place sterilized filter cup into opening of collector/dispenser bottle.

Replace Filter Cup

The filter cup should be replaced every two months or after 60-80 gallons of water processed (whichever comes first). Replace more often should the distilled water begin to have an unwanted taste or odor.

Discard first gallon of distilled water as it may contain small, harmless carbon fines. Order replacement filters from the outlet where you purchased your distiller.

Clean Boiler

- Remove boiler by grasping handle and pulling it out of chassis (fig. C).
- Remove boiler cap by turning it counterclockwise (fig. D).
- Loosen steam baffle securing nut by turning counterclockwise and remove steam baffle (fig. D).
- Wash inside of boiler with soap and water.
- Rinse thoroughly. Water should be drained through boiler spout.



IMPORTANT: Wipe off all water deposits inside the Distiller chassis and on the outside of the boiler before each distillation cycle.

USING THE COUNTERTOP DISTILLER



WARNING: Never remove the boiler while the fan motor is running, or for 30 minutes after it stops. Severe burns can result from boiling water or steam. **DO NOT** change position or location of distiller while it is operating or cooling.

FIGURE C

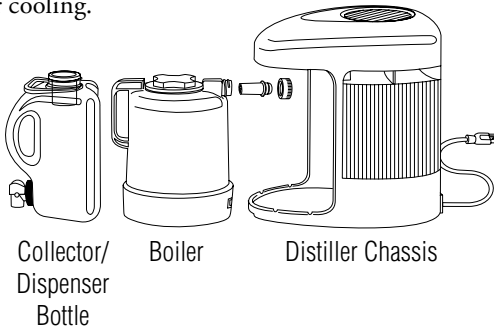

*Operational
maintenance
and replacement
requirements are
essential for this
product to
perform as
advertised.*

1. Set Distiller on dry, level, well-supported, stable surface.
2. Remove collector/dispenser bottle.
3. Remove boiler by grasping its handle and pulling it out of chassis.
4. Remove boiler cap by turning it counterclockwise (fig. D).
5. Loosen steam baffle securing nut by turning counterclockwise and remove steam baffle (fig. D).
6. Rinse boiler thoroughly before filling. The water should be drained through boiler spout.
7. Fill boiler with ordinary tap water to bottom of four tabs in boiler opening, approximately 1 gallon (3.8 Liters). These tabs indicate the **MAXIMUM FILL POINT**. **DO NOT OVERFILL** (fig. D).
8. Replace boiler cap by turning it clockwise until tight.
9. Make sure gasket is installed on long end of steam baffle and that it is snug against flange (fig D). Insert long end of baffle, **flat side down**, into the boiler spout. Turn securing nut clockwise onto spout until tight, being careful to not cross thread.



IMPORTANT: Wipe off all water deposits inside the Distiller chassis and on the outside of the boiler before each distillation cycle.

FIGURE D

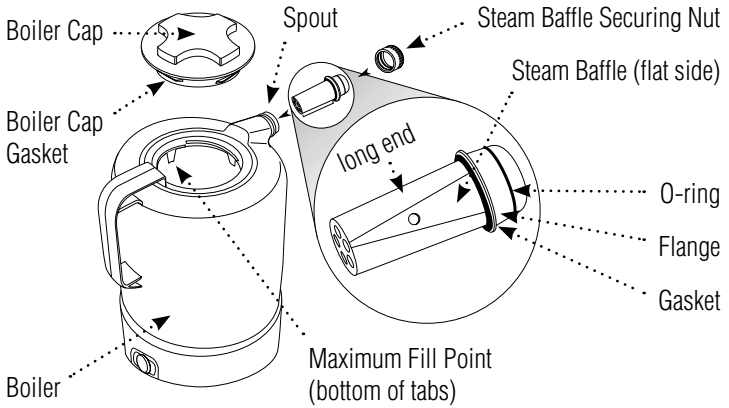

10. Slide boiler into chassis compartment and press firmly to ensure boiler is properly placed (fig. E). To prevent personal injury or property damage, the boiler must be fully engaged prior to start-up.
11. Plug power cord into a properly rated, grounded outlet.
12. Press “Start” button at base of boiler (fig. E). “Start” button will illuminate when heating; however, the light will go out and boiler will stop heating if electrical power is interrupted or stopped. If this occurs, press “Start” button again to restart the distillation cycle.
NOTE: The cooling fan will not start immediately because of a delayed fan start-up feature. The fan will start once the boiler has reached a predetermined temperature, approximately 30 to 40 minutes after starting the cycle.



WARNING: To prevent personal injury, burn and/or scald injury, **DO NOT** remove boiler while “Start” button is illuminated or at any time when the boiler is hot. Always unplug Distiller from wall outlet and allow boiler to cool completely before removing it from the Distiller (at least 30

FIGURE E

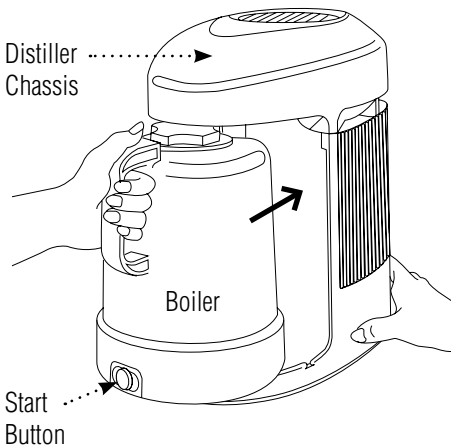

minutes). **DO NOT** change position or location of Distiller while it is operating or cooling.

13. Place prepared carbon filter cup into opening at the top of the collector/dispenser bottle. **DO NOT** install cap onto bottle (fig. F).
14. Replace the collector/dispenser bottle (fig. F). Make sure the dispensing valve is securely tightened.

FIGURE F

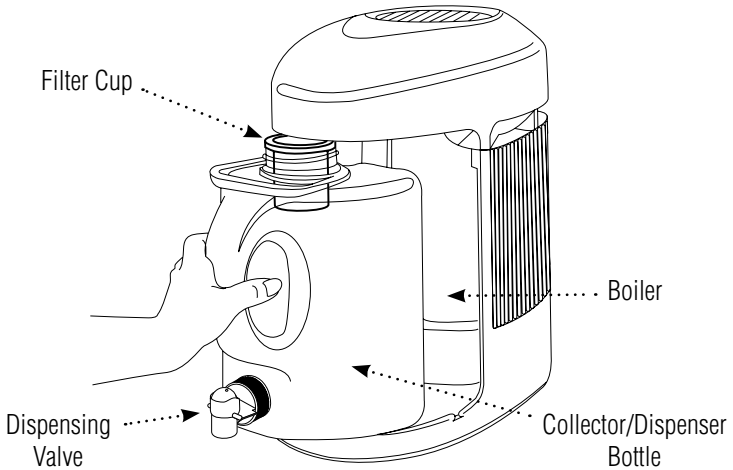

IMPORTANT: The collector/dispenser bottle must be properly placed, with its cap removed and filter cup in place, for proper water collection. **DO NOT** remove collector/dispenser bottle while Distiller is operating.

NOTE: At the end of the distillation cycle (about 4.5 hours), Distiller will shut off automatically and “Start” light will go out. The fan will continue to operate for a few minutes.

15. Unplug cord from wall outlet when not in use.
16. **DISCARD FIRST GALLON** of distilled water as it may contain some harmless matter from manufacturing and/or packaging.
17. Rinse boiler thoroughly before refilling.



IMPORTANT: Wipe off all water deposits inside the Distiller chassis and on the outside of the boiler before each distillation cycle.

NOTE: The collector/dispenser bottle will not fill completely. The collector was designed to hold 1 gallon of water and allow additional space so that the carbon filter does not remain in contact with the distilled water.

Once distillation cycle is complete, the water bottle may be placed in refrigerator and used to dispense the distilled water. The filter cup may be left in or removed and stored in the refrigerator in a sealed plastic bag or other airtight container. Secure cap onto the bottle to avoid spilling. The cap must be opened slightly before dispensing water. It is recommended that the bottle **NOT** be placed in a freezer as handle may become brittle and crack.

NOTE: Approximately 5 ounces (150 ml) of water will remain in boiler at the end of the distillation cycle. This feature reduces scale deposits in the boiler.



WARNING: To prevent personal injury or electric shock, **DO NOT** immerse the Distiller, its boiler, its cord or plugs in water or other liquid.

DISTILLER MAINTENANCE



WARNING: Always be sure to unplug power cord from wall outlet before cleaning or servicing Distiller.

Cleaning Boiler

Rinse the boiler before every distillation cycle with warm tap water to remove any loose residue. Loosen securing nut and remove steam baffle (fig. D). Half fill boiler with warm tap water, agitate and discard the water. The water should be drained through boiler spout.

Excessive deposits can cause malfunction. As scale deposits build up, use an approved cleaner, such as KLEENWISE, to remove this deposit. White vinegar or automatic coffee pot cleaner can also be used. **DO NOT** operate Distiller with cleaning solution in boiler. Use a soft plastic or nylon scouring pad if needed. **DO NOT** use abrasive cleaners, caustic acids, steel wool pads or metal utensils. Wipe outside of boiler tank with a soft cloth or sponge and mild soapy water.



IMPORTANT: Wipe off all water deposits inside the Distiller chassis and on the outside of the boiler before each distillation cycle.

Cleaning Collector/Dispenser Bottle

See page 5 for cleaning and sanitizing instructions.

Replacing Carbon Filter Cup

See page 5 for preparation and installation instructions.

Distiller Chassis Maintenance

Outside surfaces may be cleaned with common, non-abrasive household glass or appliance cleaners or warm soapy water applied to a soft cloth or sponge. The Distiller's cooling vents (fig. G) should be vacuumed occasionally or cleaned with a soft brush to remove dust and debris.

FIGURE G

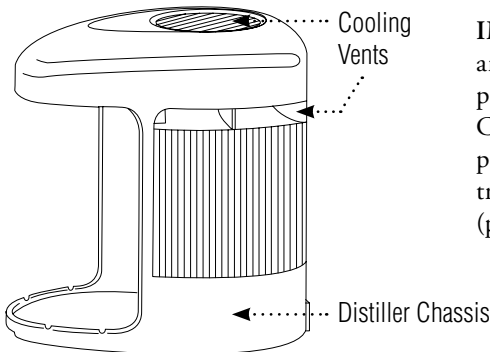

IMPORTANT: There are **NO** user serviceable parts inside Distiller. Contact qualified service personnel for repair if troubleshooting tips fail (page 10).

TROUBLESHOOTING

<i>Problem</i>	<i>Possible Cause</i>	<i>Solution</i>
“Start” button does not light up.	Distiller is not plugged in. Boiler is not fully engaged.	Plug Distiller into appropriate outlet. Make sure the boiler is properly placed (fig. E).
“Start” button lights up, but fan does not start.	Fan delayed start system has not activated the fan.	Wait about 30 minutes for the fan to start.
Distiller does not operate.	Distiller is not plugged in. Electrical power interruption. Outlet is defective or fuse or circuit breaker has tripped.	Plug Distiller into appropriate outlet. Press “Start” button to restart. Check fuses or circuit breakers or call an electrician.
The distilled water has an unusual taste.	The carbon filter is contaminated. The collector/dispenser bottle needs cleaning. The boiler has been overfilled.	Replace the carbon filter cup (page 5). Clean the bottle (page 5). DO NOT overfill boiler. Fill to bottom of four tabs in boiler opening (fig. D).
Steam appears inside chassis above boiler.	Steam baffle missing or improperly installed. Boiler cap missing or loose. Boiler cap gasket missing or defective.	Properly install steam baffle and steam baffle securing nut (page 6, #9). Tighten boiler cap. Replace gasket.
Water leaking from Distiller.	Cap is on collector/dispenser bottle. Dispensing valve loose.	Remove cap from bottle during distillation cycle. Tighten dispensing valve.
No power to boiler.	Boiler not fully engaged in chassis.	Make sure the boiler is properly placed (fig. E).
Early shut off.	Electrical power interruption. Excessive deposits in boiler.	Press “Start” button to restart. Clean boiler (page 9).
Early shut off and/or water under boiler.	Steam baffle improperly inserted. O-ring worn or defective.	Properly install steam baffle and steam baffle securing nut (page 6, #9). Replace o-ring.

PRACTICAL USES FOR CLEAN DISTILLED WATER

Drinking...

it's healthy and delicious

Complexion Care...

daily cleansing without pore clogging impurities

Cooking...

enhances natural taste and appearance without unsavory chemicals

Aquariums...

fish thrive in a clean, clear, chlorine-free tank

Houseplants...

*eliminate brown tips on foliage and salt deposits on flower pots—
enjoy blooms longer*

Coffee, Tea & Cocoa...

you'll enjoy truer, richer flavors while using less

Fruit Juices...

experience the freshly squeezed, natural flavor

Low Sodium Diets...

up to 99.9% sodium free

Steam Irons & Humidifiers...

no damaging scale buildup means longer product life

Ice Cubes...

crystal clear and sparkling—won't spoil your drink

Pet Care...

pets will enjoy the same benefits people do

Baby Formulas...

pure enough for formulas, inhalation therapy and herbal tinctures

and many other uses you'll discover...

WARRANTY REGISTRATION CARD

Please fill out and return the enclosed registration card or register online at
www.waterwise.com/warranty

Registration will not affect warranty coverage, but may expedite processing of your warranty. Registration is the only way to guarantee you will be notified by Waterwise of any issues that arise concerning this product.

OWNER'S LIMITED WARRANTY

Waterwise warrants, to the original purchaser, this product against defects in materials and workmanship, excluding the disposable carbon filter and gasket, for a period of one (1) year from the date of purchase. Defects or failures due to shipping/handling, improper use or maintenance, including abuse or neglect, normal wear, water conditions, accidents, alterations or modifications, or unauthorized repair are specifically excluded from this warranty. No dealer, distributor, agent, representative, or other person is authorized to extend or expand this warranty.

Waterwise is not responsible or liable for personal injury, property damage, or incidental or consequential damages arising out of, or in connection with, the use or performance of the product or other damages with respect to loss of use, or costs of removal, installation, or reinstallation.

Waterwise will, at its option, replace or repair the defective part(s) without charge, provided they are returned, transportation prepaid by owner, to an authorized service facility or to the address below. Enclose a letter describing the problem, copy of dated proof of purchase, and your name, address and daytime telephone number.

This limited warranty does not guarantee uninterrupted service. Repair or replacement as provided under this warranty is the exclusive remedy of the purchaser. This limited warranty is in lieu of all other warranties, expressed or implied, including, but not limited to, any implied warranty of merchantability or fitness for a particular use or purpose. This warranty gives you specific legal rights and you may also have other rights which vary from state to state or province to province. Outside the United States, a different warranty may apply. For details, please contact your authorized Waterwise distributor.

If your distiller fails to function properly or requires service, please contact your authorized distributor to arrange for service and/or replacement parts.



3608 Parkway Blvd • Leesburg Florida 34748-9399 • (352) 787-5008 • Fax: (352) 787-8123
www.waterwise.com • E-mail: service@waterwise.com